

# ACT I

## BACKPACK CAPACITY UPGRADES

- Hightown – Robes by Jean Luc
- Lowtown – Apparel Shop

## COMPANION UPGRADES

- Aveline – Underpadding – Lowtown Day: Armor Merchant shop
- Bethany/Carver – Protective Sigils / Fereldan Girded Plating – Quest: Birthright, Crate in last room
- Varric – Inscribed Leather Harness – Lowtown Day: Apparel shop

## COMPANION GIFTS

- Bethany/Carver – Portrait of Your Mother / Tobrius's Documents – Quest: Birthright, Crate in cellar

## CRAFTING RECIPES – found/made

- Combustion Grenade - Quest: Blackpowder Promise, Body of Tal-Vashoth
- Crow Venom - Black Emporium (DLC): Buy
- Deathroot Toxin - Docks Day, Buy from Shady Merchant
- Debilitating Poison – Darktown: Gift from Thomwise
- Elfroot Potion - Lowtown Day: Gift from Lady Elegant
- Elixir of Purity - Black Emporium (DLC): Buy
- Restoration Potion - Gallows Day: Buy from Formari Herbalist shop
- Rune of Fire - Quest: The First Sacrifice, Find in Dark Foundry
- Rune of Fire Warding - Wounded Coast: Pile of bones in peninsula ruins
- Rune of Fortune - Black Emporium (DLC): Buy
- Rune of Frost - Lowtown Day: Buy at Lirene's Fereldan Imports
- Rune of Frost Warding - Quest: Enemies Among Us, Found in Sanctuary
- Rune of Impact - Quest: Enemies Among Us, Found in Wilmod's camp
- Rune of Lightning - Sundermount Outside: Bones at top, OR Chest at Blooming Rose
- Rune of Lightning Warding - Gallows Day: Buy at Mage's Goods shop
- Rune of Protection - Hightown Day: Gift from Worthy the first time you talk to him
- Tar Bomb - Docks Day: Buy from Shady Merchant

## CRAFTING RESOURCES

### KIRKWALL

- Darktown Day, South - Deathroot
- Sanctuary(quest) - Deathroot
- Docks Night, Disused Passage - Deathroot
- Lowtown Day, East - Spindleweed
- Deep Roads - DeepMushroom, DeepMushroom, Lyrium, Lyrium, Orichalcum, Silverite

### FREE MARCHES

- Bone Pit - Elfroot
- Bone Pit Mines - DeepMushroom, Lyrium
- Dead Man's Pass(quest) - Embrium
- Runaway's Cavern(quest) - Lyrium
- Sundermount - DeepMushroom, Elfroot, Elfroot
- Caverns - Silverite
- Ambush Site(quest) - Elfroot
- Vimmark Mountain Pass(quest) - Silverite
- Wounded Coast - Elfroot, Elfroot, Glitterdust, Spindleweed
- Slaver Caverns(quest) - DeepMushroom, Spindleweed
- Tal-Vashoth Cavern - Lyrium, Silverite

## FETCH & RETRIEVE QUESTS

- Bottled Scar 5:34 Exalted – Viscount's Keep ,office, desk
- Caste Treatise and House Accounting – Dead Man's Pass, corpse
- Eustice's Pommel – Bone Pit, mines sack
- Grimroire of the Apprentice – Darktown, Sanctuary, sack
- Locks of the Golden Fool – Chantry, upstairs, book
- Map of Occupied Kirkwall – Sundermount, crate
- The Paragon's Toe – Hightown, Blooming Rose, upstairs crate
- Redblossom Special – Wounded Coast, crate
- Remains of the Outlaw “Bearded Beast” – Bone Pit, corpse
- Remains of the Outlaw Half-Braid Silsam – Docks, Disused Passage, remains
- The Remains of Sister Plinth – Darktown, remains
- The Seal of House Talwain – Sundermount Passage, crate
- Shawl of Dalesdottir – Hanged Man Day, chest

## EXPLORATION

### KIRKWALL

- |                 |     |       |              |
|-----------------|-----|-------|--------------|
| Black Emporium  | Day |       |              |
| Darktown        | Day |       |              |
| Docks           | Day | Night | Gang         |
| Disused Passage |     | Night |              |
| Gallows         | Day |       |              |
| Hightown        | Day | Night | Gang         |
| Blooming Rose   | Day | Night |              |
| Chantry         | Day | Quest |              |
| Keep            | Day | Quest |              |
| Lowtown         | Day | Night | Gang         |
| Gamlen's House  | Day |       |              |
| Hanged Man      | Day | Night | Friend H L D |
- FREE MARCHES
- |               |       |
|---------------|-------|
| Bone Pit      | Visit |
| Sundermount   | Visit |
| Wounded Coast | Visit |

## MAIN PLOT QUESTS

- A Business Discussion
- A Friend in the Guard
- A New Home?
- Act of Mercy
- Blackpowder Promise
- Enemies Among Us
- Friends in Low Places (*after all others completed*)
- Long Way Home
- Shepherding Wolves
- Wayward Son

## SECONDARY QUESTS

- An Errant Letter
- Bait and Switch
- The Bone Pit
- Fools Rush In
- Finders Keepers
- The First Sacrifice
- Get Back to Work
- Herbalist's Tasks
- Loose Ends
- Magistrate's Orders
- The Unbidden Rescue

## SIDE QUESTS

- Changing One's Nature (*DAO: sided with werewolves*)
- The Conspirators (*DAO: if Vigil's Keep survived*)
- Dark Epiphany (*DAO: Avernus left alive*)
- Last of His Line (*DAO: Bhelen was king*)
- Miracle Makers (*DAO: didn't defile ashes & Genitivi expedition*)
- Night Lies
- Pier Pressure
- Secret Rendezvous
- Sharp Little Pinpricks
- Terror on the Coast (*DAO: If Sophia survived*)

## COMPANION QUESTS

- Anders
  - Talk to Anders
  - Tranquility
- Aveline
  - The Way it Should Be
- Bethany/Carver
  - Birthright
  - Portrait of the Past / Family History
- Fenris
  - Fenris Recruited
- Isabela
  - Isabela's Contract
- Merrill
  - Welcome Home
  - Nice Crime You Have Around Here
- Sebastian
  - Duty
- Varric
  - Questions and Answers

# ACT II

## BACKPACK CAPACITY UPGRADES

- Hightown – Robes by Jean Luc
- Gallows – Mage Goods

## COMPANION UPGRADES

### Anders

- Lyrium Weave: Gallows – Mage Goods
- Armor Struts: Lowtown – Lirene's Fereldan Imports
- Spirit Essence: Quest: Dissent – Gallows Dungeon

### Aveline

- Flex-Chain: Quest: Raiders on the Cliffs – Fell Orden
- Impact Plating: Lowtown – Armor Merchant

### Fenris

- Lyrium Scales: Docks – Shady Merchandise
- Tevinter Spirit Symbol: Hightown - Robes by Jean Luc
- Reinforced Straps: Quest: A Bitter Pill – Abandoned Slaver Den

### Isabela

- Lambswool Insoles: Quest: To Catch a Thief – Lost-End Foundry
- Rigid Boning: Lowtown – Apparel Shop
- Supportive Corset: Hightown – Robes by Jean Luc

### Merril

- Silver-Threaded Embroidery: Sundermount Outside – top of the path
- Carved Ironwood Buttons: Sundermount Outside - Ilen's Crafts
- Samite Lining: Hightown – Robes by Jean Luc

### Sebastian

- Enchanted Articulation: Gallows – Armor Shop
- Mail Undertunic: Quest: Repentance – Harriman Estate
- Reinforced Bracers: Hightown – Olaf's Armory

### Varric

- Inscribed Leather Harness: Lowtown – Apparel Shop
- Silverite-Reinforced Buckles: Quest: Family Matter – Bertrand's Estate
- Coat Lining with Pockets: Docks – Shady Merchandise

## COMPANION GIFTS

- Anders – Tevinter Chantry Amulet – Quest: A Bitter Pill, Abandoned Slaver Den
- Aveline – Shield of the Knight Herself – Quest: Offered and Lost, Ser Vernel's Refuge
- Fenris – A Slave's Life – Lowtown Night: Sack in the Elven Alienage
- Isabela – Ship in a Bottle – Quest: Blackpowder Courtesy, Smuggler's Cut
- Merrill – Wooden Halla Carving – Sundermount Outside: Buy at Ilen's Craft shop
- Sebastian – Strakhaven Longbow – Quest: Repentance, Found in Harimann Estate
- Varric – The Tethras Signet Ring – Lowtown Day: Buy at Trinkets Emporium

## CRAFTING RECIPIES – found/made

- Arcane Poison - Quest: Blackpowder Courtesy, Loot from Elven Fanatic in Side Alley
- Elixir of Heroism - Quest: Demands of The Qun, Hightown
- Life Ward Potion - Gallows: Buy from Formari Herbalist shop
- Mighty Offense Potion - Sundermount Outside: Pile of Bones near graveyard
- Mythal's Favor - Wounded Coast: Crate outside a blocked cave
- Rock Armor Potion - Lowtown Night: Pile of Rubble next to Gamlen's house
- Rune of Defense - Wounded Coast: Find on a skeleton
- Rune of Nature - Sundermount Outside: Buy at Ilen's shop
- Rune of Nature Warding - Quest: Blackpowder Courtesy, Find at Smuggler's Cut
- Rune of Spirit - Quest: Inside Job, Find in Brekker's Hideaway
- Rune of Spirit Warding - Gallows: Buy at Mage Goods Shop
- Rune of Striking - Quest: Prime Suspect, Find in DuPuis Estate

## CRAFTING RESOURCES

### KIRKWALL

- Darktown outside Clinic - Deathroot
- Smuggler's Cut (quest) - DeepMushroom, Silverite
- The Killers Lair(quest) - Orichalcum
- Gallows Dungeon(quest) - DeepMushroom, Spindleweed

### Lowtown, East - Spindleweed

### Black Emporium – Spindleweed

### FREE MARCHES

- Bone Pit - Deathroot, Glitterdust
- Mines - CorruptedLyrium
- Rotting Cove(quest) - CorruptedLyrium
- Sundermount - Elfroot, Embrium, Glitterdust
- Sundermount Caverns - Orichalcum, Orichalcum, Silverite
- Varterral Hunting Ground(quest) - DeepMushroom, Glitterdust, Orichalcum
- Wounded Coast - Elfroot, Embrium, Embrium
- Dank Cave(quest) - Lyrium
- Holding Caves(quest) - Embrium, Glitterdust

## EXPLORATION

### KIRKWALL

- Black Emporium Day
- Darktown Day
- Docks Day Night Gang
- Disused Passage Night
- Gallows Day
- Hightown Day Night Gang
- Blooming Rose Day Night
- Chantry Day Quest
- Keep Day Quest
- Lowtown Day Night Gang
- Gamlen's House Day
- Hanged Man Day Night Friend H L D

### FREE MARCHES

- Bone Pit Visit
- Sundermount Visit
- Wounded Coast Visit

## MAIN PLOT QUESTS

- Profit and Loss (*if Friends in Low Places was accepted*)
- Blackpowder Courtesy
- Offered and Lost
- Prime Suspect
- All That Remains
- Following the Qun
- To Catch a Thief (*If Isabela recruited*)

## SECONDARY QUESTS

- Cave Crawling
- Cavern of Dead
- Fool's Gold (*DAO: if Nathaniel died*)
- Herbalist's Tasks
- Inside Job
- Night Terrors (see puzzle, above)
- Pick Up Pickaxes
- Raiders on the Cliffs

## SIDE QUESTS

- A Debt in the Family (*if pro templar in Act 1*)
- Bounty Hunter(*if pro templar in Act 1*)
- Elves at Large(*if pro templar in Act 1*)
- The Fixer
- Forbidden Knowledge
- Goosegirl Cameo(*if pro templar in Act 1*)
- Hometown Breed
- Honoring the Fallen
- How to Frame a Templar(*if pro mage in Act 1*)
- Ladies' Lights Out
- The Lost Patrol
- The Lowdown
- The Midnight Meeting(*if pro mage in Act 1*)
- Search and Rescue(*if pro mage in Act 1*)
- Sketchy on the Details
- The Underground Railroad(*if pro mage in Act 1*)

## “FORBIDDEN KNOWLEDGE” QUEST

*Note: You must DESTROY the books, otherwise the quest bugs out and can't be completed.*

### Evil Tome Locations:

- Chantry: upstairs
- Viscount's Keep: hall before Throne room
- Bone Pit: Cave
- Wounded Coast: Dank Cave
- Sundermount: Recently Opened Passage
- Darktown: Evil Pit for the Fel Grimoire (*after all others*)

## “NIGHT TERRORS” QUEST BARREL PUZZLES

layout: A B C D

E F G H

solve: C G F B A E F B C G H D

layout: A B C D E F

G H I J K L

solve: B H E K G A L F B C E D I H J K

## FETCH & RETRIEVE QUESTS

- The Eyes of Azure Jamos – Sundermount Summit, mage's corpse
- Lyrium-Laced Bilge Hoop – Deep Roads barrel (*DAO: if Nathaniel died*)
- The One True Pantaloons – Quest: Dissent, dwarf corpse
- Ream-Rot Knife – Sundermount, either Caverns sack or Summit recess
- Seal of the Old God Dumat – Docks Disused Passage, crate
- “South-Song” Gerralt's Corpse – Sundermount Thaig, corpse
- Swatch of the Jackyard – Quest: Raiders on the Cliffs, Fel Orden's corpse
- Waxler's Hat - Docks Disused Passage, sack
- Wentworth's Sixth Finger – Bone Pit, sack

## COMPANION QUESTS

- Anders
- Visit Anders
  - Dissent
  - Questioning Beliefs
  - Anders in the Fade (*if taken to fade*)
- Aveline
- Calling on the Captain
  - The Long Road
  - Questioning Beliefs
  - Doubts that Linger (*if taken to fade*)
  - The Captain's Condolences
- Fenris
- Speak to Fenris
  - Questioning Beliefs
  - A Bitter Pill (go to Free Marches with Fenris)
  - Fenris Night Terrors(*if taken to fade*)
- Isabela
- Isabela's Ongoing Search
  - Questioning Beliefs
  - Isabela's Apology (*if taken to fade*)
- Merrill
- Consoling Words (*if sibling NOT taken to Deep Roads*)
  - Mirror Image
  - Back from Sundermount
  - Questioning Beliefs
  - Merrill, An Apology(*if taken to fade*)
- Sebastian
- Repentance
  - Questioning Beliefs
- Varric
- Plans for the Future
  - An Update
  - Family Matter
  - Story Being Told/Rumor Making Rounds
  - Varric's Apology(*if taken to fade*)
  - Friendly Concern (*after consummating a relationship*)

END OF ACT II

## MARK OF THE ASSASSIN DLC

### TILE PUZZLES

#### Facing the fire:

Northern	Western	Eastern
X_X_X	_X_X_	X_____
XXX_X	_XXX_	XXXXX
X_X_X	_X_X_	X_____

#### BIG ONE in East

A	B	—	—	—
C	D	—	E	F
—	—	G	H	I
—	J	K	L	—
—	M	N	—	O

### CAPRICES

- There are 5:
- 3 laying outside
  - 1 bought from quartermaster
  - 1 from Cyril as part of main quest

### HARD TO STOMACH

- 4 Lutefisks
- 3 Slices of Cheese
- 5 Navets

## LEGACY DLC

### TORCH ROOM ORDER

(altar)

X	X
1/5	2
4	3/6

### HAWKE'S KEY EXPLOIT

- HOLD: Place each party member in front of a pillar.
- PAUSE: In turn, switch between each character and click each pillar.
- UNPAUSE: The animation will play 4 times (the first time is also followed by a conversation each time)

### NEXUS PUZZLE – only if you side with Larius

After activating the four Power Nexi, return and align bottom nexi thusly:

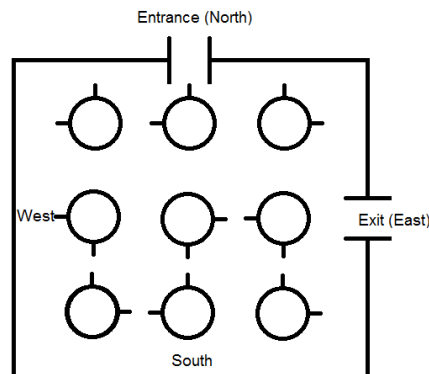

image from dragonagecenter.blogspot.com

# ACT III

## BACKPACK CAPACITY UPGRADES

- Hightown – Robes by Jean Luc

## COMPANION UPGRADES

- Anders – Sigil of Mage Underground – Quest: Best Served Cold, Secret Meeting Place
- Aveline – Deflecting Joints – Quest: Favor and Fault, on Jeven's corpse
- Fenris – Enchanted Resin – Quest: Mine Massacre, on the Dragon
- Isabela – Boiled Leather Plates – Quest: A Murder of Crows
- Merrill – Halla Horn Buckles – Quest: A New Path, on Pride Demon's corpse
- Sebastian – Protection of the Faith – Quest: Best Served Cold, Hightown Night
- Varric – Drakeskin Leg Straps – Quest: Finding Nathaniel (*DAO: if Nathaniel survived*)

## COMPANION GIFTS

- Fenris – Blade of Mercy – Quest: Best Served Cold, in Secret Meeting Place
- Isabella – Rivani Talisman – Docks Night: in Dissuaded Passage
- Merrill – Sylvanwood Ring – Quest: Murder of Crows, on Thief Leader

## CRAFTING RECIPES – found/made

- Fell Grenade - Wounded Coast: Peninsula Ruins, crate
- Fell Poison - Quest: On The Loose, on Huon
- Rune of Devastation - Quest: On The Loose, Chest in Sewer Passage
- Rune of Valiance - Sundermount Outside: western ruins

## CRAFTING RESOURCES

### KIRKWALL

- Darktown – Deathroot
- Lowtown Foundry – Spindleweed
- Docks: Castillon's Landing (quest) – Ambrosia

### FREE MARCHES

- Bone Pit
  - High Dragon (quest) - Dragon Blood
  - Drakestone Mines (quest) – DeepMushroom
- Sundermount
  - Outside – GlitterDust
  - Pride's End (quest) – Felendaris
  - Caverns - Lyrium, Orichalcum
- Wounded Coast - Elfroot, Embrium

## “LOST SWORDS” QUEST

### KIRKWALL

- Anders' Clinic: Crate
- Docks Night: Bones in Harbormaster's Area
- Docks Night: Western Warehouse District Locked Chest
- Gallows: Weapon Shop
- Hightown Day: Korval's Blades
- Hightown Night: Quest: On the Loose, in Compt de Launce's Mansion
- Lowtown Day: Weaponsmithy
- Lowtown Night: Rubble in Foundry Area

### FREE MARCHES

- Wounded Coast: Camp bones at top of mountain
- Wounded Coast: In camp bones to NW

## “AWIERGAN SCROLLS” QUEST

### First Aspect

The Wounded Coast, head south from the entrance to the first dead end path on the left. The Scroll is next to a corpse found at the end. Your journal will update telling you that a new "Hidden Lair" has opened, but the location is out in the open, just past the branch leading down to the peninsula ruins.

### Third Aspect

(actually found before the 2nd) Located in Sundermount Outside before reaching the Dalish Camp. After getting the scroll, go up the path up the mountain. There should be an Arcane Horror waiting for you.

### Second Aspect

In Sundermount Outside, found in the area where you fought the Arcane Horror behind one of the walls at the ruins. Your journal will update telling you a new "Hidden Lair" has opened, but it's outside. Go through the Passage and past the Mountain Graveyard. Partway up you'll fight three daemons and their entourage.

### Pride Unbound

Near Ander's Clinic, it's the same door used for the Quest "Birthright" in Act I. Inside the lair, you will encounter a Pride Demon named Hubris. Kill it and its minions.

## EXPLORATION

### KIRKWALL

- Black Emporium Day
- Darktown Day
- Docks Day Night Gang
- Disused Passage Night
- Gallows Day
- Templar Hall Day
- Hightown Day Night Gang
- Blooming Rose Day Night
- Chantry Day Quest
- Keep Day Quest
- Lowtown Day Night Gang
- Hanged Man Day Night Friend H L D

### FREE MARCHES

- Bone Pit Visit
- Sundermount Visit
- Wounded Coast Visit

## MAIN PLOT QUESTS

- Best Served Cold
- On the Loose

## SECONDARY QUESTS

- A Murder of Crows (*DAO: Zevran Arainai survived*)
- Finding Nathaniel (*DAO: Nathaniel Howe survived*)
- Gamlen's Greatest Treasure
- Herbalist's Tasks
- Mine Massacre
- Visit Gamlen

## SIDE QUESTS

- A Noble Agenda (*if sided with Orsino in Act opening*)
- The Awiergan Scrolls (see left)
- Beware of Dog
- King Alistair (*DAO: Alistair was made king*)
- The Last Holdouts (*if sided with Meredith in Act opening*)
- The Lost Swords
- Who Needs Rescuing? (*if Feynriel sent to Tevinter*)

## COMPANION QUESTS

### Anders

- Check on Anders
- Justice
- Questioning Beliefs

### Aveline

- Champions and Captains
- Favor and Fault
- Questioning Beliefs

### Fenris

- Speak to Fenris
- Alone
- Questioning Beliefs

### Isabela

- Isabela's Regret (*if relic returned*)
- No Rest for the Wicked
- Questioning Beliefs

### Merrill

- The New Place (if romanced)
- A Talking To
- A New Path
- Merrill, Friend or Foe? (100% friend/rival)

### Sebastian

- Faith
- Questioning Beliefs

### Varric

- The Storm and What Came Before It
- A Small Problem
- Haunted
- Closure
- An Anniversary